



FLOWMETERS



Direct reading flowmeters type RM

The direct reading flowmeters type RM are flow measuring devices suitable for small flows of liquid and gaseous fluids. The measure cone is got directly from the acrylic body of the flowmeter. They can have three different constructions: with square connections (with or without needle valve) [execution 1], with lateral [execution 2] or

frontal connections with needle valve [execution 3]. Their working principle is very simple and they are particularly suitable for gas-therapy, purge, analysis and level measurements.

Other features, besides the ones already mentioned, are:

- connections and needle valve made of brass or stainless steel AISI 316;
- bodies with different sizes depending on use to be made at request.

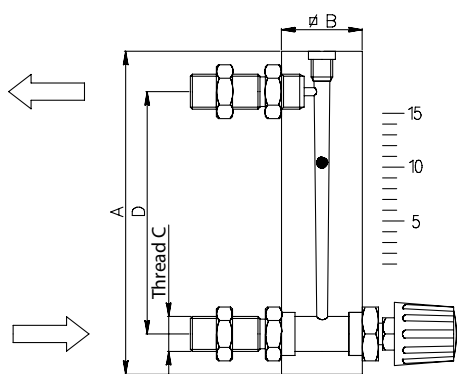

Execution 1
With square connections

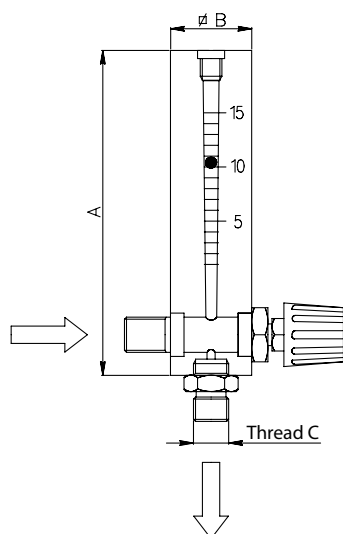

Execution 2
With lateral connections

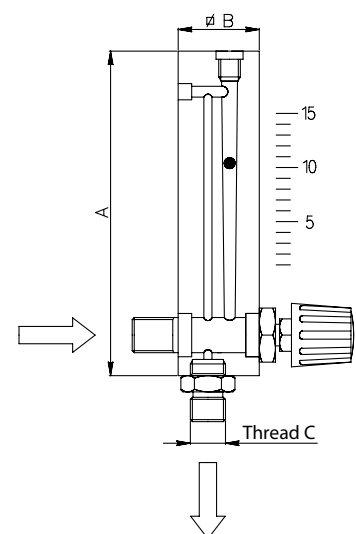

Execution 3
With frontal connections



FEATURES

Accuracy	± 10% V.F.S.
Working max. pressure	10 bar
Working max. temperature with standard gaskets	50° C.
Connections made of chrome-plated brass or of AISI 316	

ACCESSORIES

Differential pressure regulator
Connections for tubing
Outlet adjusting needle valve (only for construction type "1")

TYPE	A	B	Q WATER L/h		Q AIR NL/h 1013 mbar		THREAD C	D	CONSTRUCTION
			MIN	MAX	MIN	MAX			
RM/95	95	26	5	50	60	900	G1/4" G3/8"	65	1
RM/100	100	26	5	50	60	1200	G1/4" G3/8"	70	1
RM/105	105	30	5	80	60	1800	G1/4" G3/8"	75	1
RM/120	120	30	6	120	60	3000	G1/4" G3/8"	90	1-2-3
RM/145	145	30	10	120	90	6000	G1/4" G3/8"	115	1-2-3
RM/185	185	30	50	200	300	6000	G1/4" G3/8"	155	1
RM/V	120	30	-	-	1	60	G1/4" G3/8"	90	1



Direct reading flowmeters type RG - RG/L

The flowmeters type RG-RG/L are instant flow measuring devices, suitable for small and medium flows of liquid and gaseous fluids. The flow measurement can be read with good accuracy on the graduated scale inprinted on the flowmeter body. The measure cone is got directly from the acrylic body.

They can be made with threaded connections. Another feature, besides the ones already mentioned, is:

- possibility of mounting the flowmeter anywhere along the pipeline without need of straight lines or flow correctors.

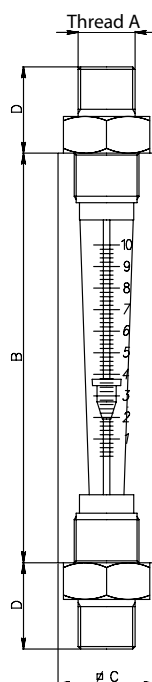



FEATURES

Accuracy	± 10% V.F.S.
Working max. pressure	10 bar
Working max. temperature	50° C.

Connections made of chrome-plated brass, AISI 316 or PVC

ACCESSORIES

Connections for tubing

TYPE	AIR Maximum flow Nm³/h 1013 mbar	WATER Maximum flow L/h	THREAD A	B	C	D
RG 1	10	600	G 3/8" - G 1/2"	127	35	34
RG 1/L	10	600	G 3/8" - G 1/2"	200	40	34
RG 2	25	2000	G 1/2" - G 3/4" - G 1"	160	40	40
RG 3	40	4000	G 3/4" - G 1"	190	45	40
RG 3/L	40	4000	G 3/4" - G 1"	219	60	40
RG 4	100	12000	G 1" - G 1" 1/4 - G 1" 1/2	190	60	40
RG 4/L	150	12000	G 1" - G 1" 1/4 - G 1" 1/2	254	68	53



Direct reading flowmeters type RG/S - RG/R

The flowmeters type RG/S-RG/R are instant flow measuring devices, suitable for small and medium flows of liquid and gaseous fluids. The flow measurement can be read with good accuracy on the graduated scale inprinted on the flowmeter body. The measure cone is got directly from the acrylic body. They can be made with threaded and

square connections, with or without needle valve. Another feature, besides the ones already mentioned, is:

- possibility of mounting the flowmeter anywhere along the pipeline without need of straight lines or flow correctors.

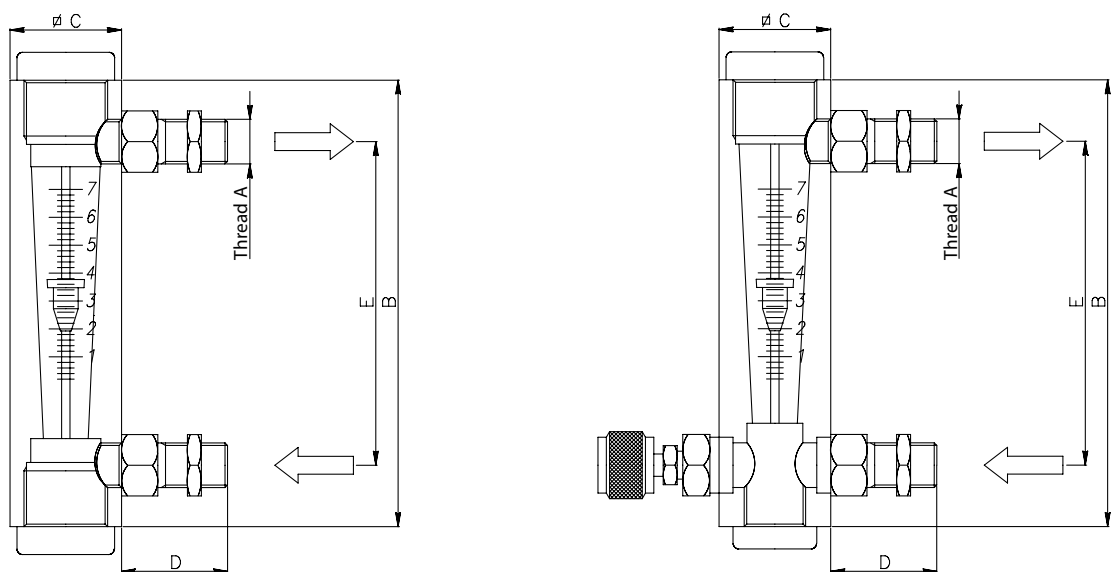



FEATURES

Accuracy	± 10% E.O.S.
Working max. pressure	10 bar
Working max. temperature	50° C.
Connections made of chrome-plated brass or of AISI 316	

ACCESSORIES

Outlet adjusting needle valve (only for construction type RG 1/L/R)
Connections for tubing

TYPE	AIR Maximum flow Nm ³ /h 1013 mbar	WATER Maximum flow L/h	THREAD A	B	C	D	E
RG 1/S	10	600	G 3/8" - G 1/2"	133	35	38	95
RG 1/L/S	10	600	G 3/8" - G 1/2"	200	40	38	140
RG 2/S	25	2000	G 3/8" - G 1/2"	160	40	38	116,5
RG 3/S	40	4000	G 3/4" - G 1"	190	45	40	120
RG 3/L/S	40	4000	G 3/4" - G 1"	219	60	40	161
RG 1/R	10	600	G 3/8" - G 1/2"	145	35	38	110
RG 1/L/R	10	600	G 3/8" - G 1/2"	200	40	38	153,5
RG 2/R	25	2000	G 3/8" - G 1/2"	160	45	38	121



Flowmeters ED series

With the flowmeters in the ED series, the user is guaranteed easy and immediate display of the minimum and maximum flow rates through flow rate indicators, fixed sliding along the graduated scale. The flowmeters in the ED series guarantee considerable savings in purchase and maintenance costs, whilst ensuring technical contents of a higher level than traditional flowmeters.

Maintaining the flow rate ranges unchanged, the ED series guarantees perfect interchangeability with the RG series flowmeters. After installation, the specific configuration of the flowmeters allows the measurement cone and relative internal components to be removed, making maintenance and cleaning easier and reducing the system stoppage times and costs to a minimum.

The technopolymer used to manufacture the flowmeters in the new ED series guarantees high chemical-mechanical resistance of the device (compatibility with a large part of the fluids used in the different industrial applications) and allows installations with working temperatures up to 120°C.

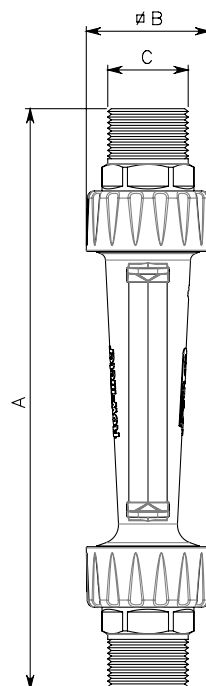



CHARACTERISTICS

Accuracy	± 5% V.F.S.
Working max. temperature	120° C.
Working max. pressure	25 bar at 15° C.
Body and connections construction material	PSU
Customised graduated scales available on request.	

TYPE	AIR Maximum flow Nm ³ /h 1013 mbar	WATER Maximum flow L/h	A	B	THREAD C
ED 1	10	600	195	43	G 3/8" - G 1/2" - G 3/4"
ED 2	25	2000	240	51	G 1/2" - G 3/4" - G 1"
ED 3	50	4000	270	59	G 3/4" - G 1" - G 1 1/4"

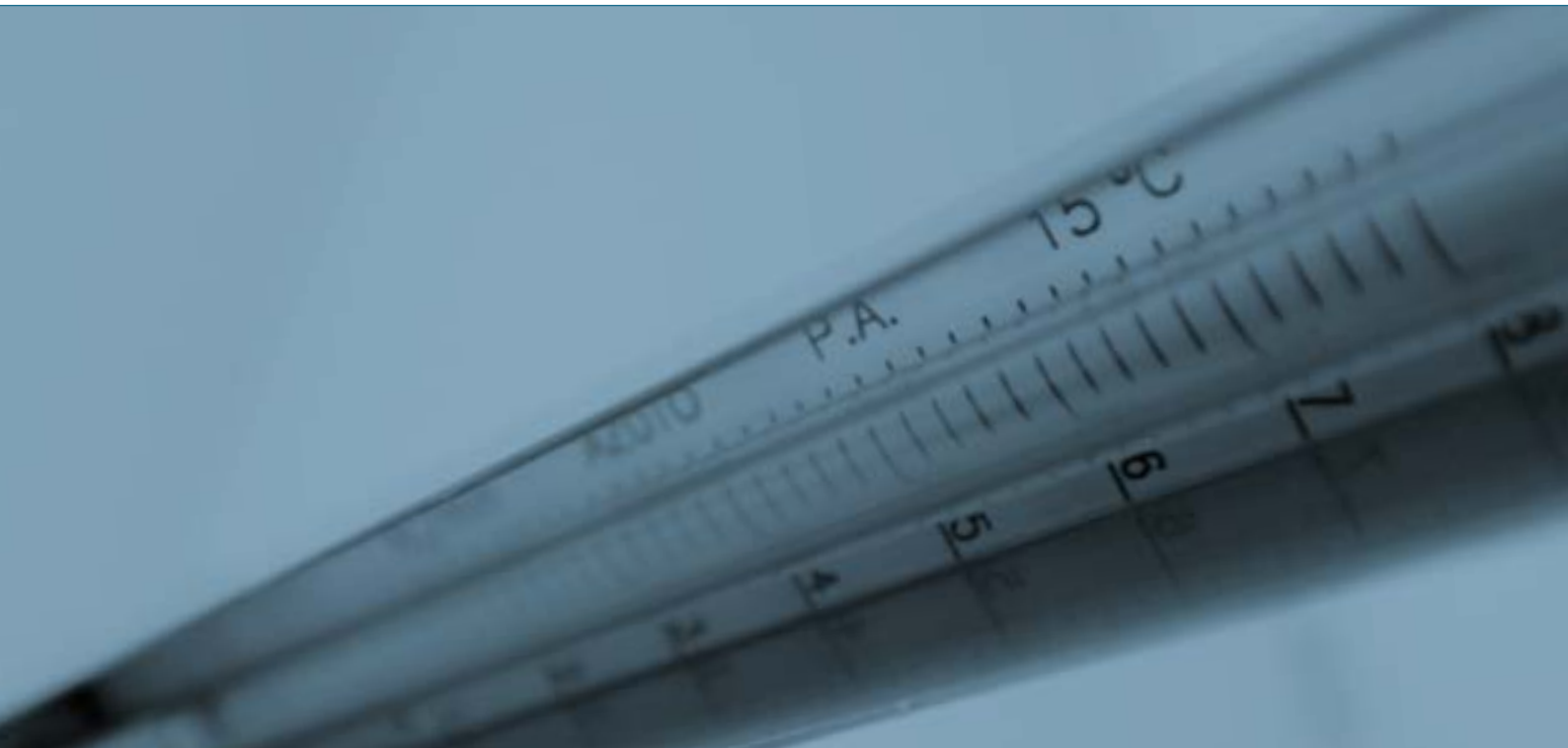

Direct reading flowmeters type LB

The flowmeters type LB are instant flow measuring devices suitable for little flows of liquid and gaseous fluids. The flow measurement can be read with great accuracy on the graduated scale which can be fixed behind the conical borosilicate JENA glass tube. The bodies can have square connections for

panel mounting, with or without needle valve, or axial connections, without needle valve. Other features, besides the ones already mentioned, are:

- metal back protection;
- resistance to high changes of temperature.

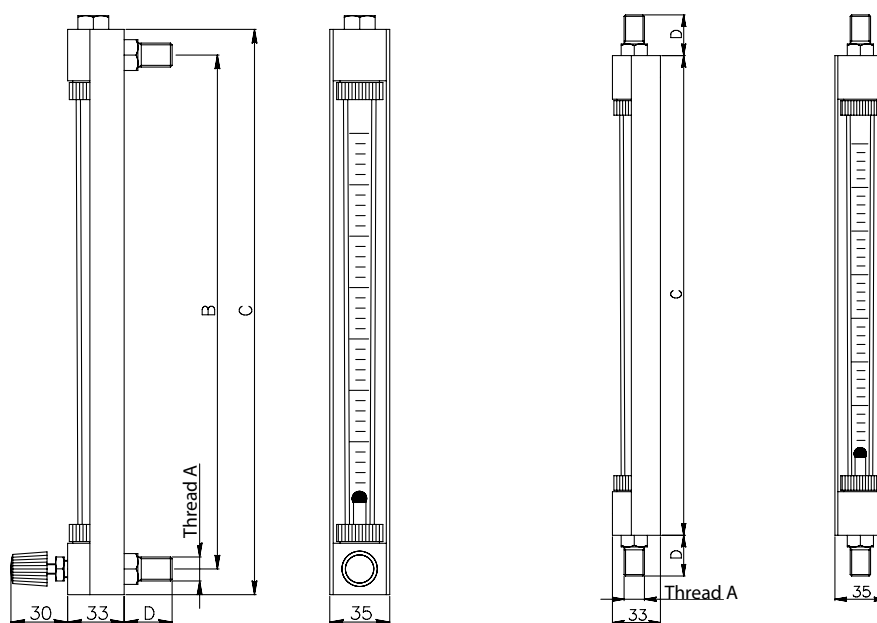

Square connections

Axial connections



FEATURES

Accuracy	± 5% V.F.S.
Working max. pressure	10 bar
Working max. temperature with standard gaskets	metal body: 120° C.
Adjusting needle valve (only for constructions with square connections and metal body)	

ACCESSORIES

Adjusting alarm photocell type "A"
PMMA front cover
P.T.F.E. gaskets

TYPE	AIR Maximum flow NL/h 1013 mbar	WATER Maximum flow L/h	THREAD A	B	C	D	GLASS TUBE
LB 2	40	1,5	G 1/4" - G 3/8"	324	350	30	3x3,5x300
LB 3	200	7	G 1/4" - G 3/8"	324	350	30	3x4x300
LB 4	350	12	G 1/4" - G 3/8"	324	350	30	4x5x300
LB 5	450	15	G 1/4" - G 3/8"	324	350	30	6x7x300
LB 6	1000	35	G 1/4" - G 3/8"	324	350	30	8x9x300
LB 7	3000	100	G 1/4" - G 3/8"	324	350	30	10x12x300
LB 8	4000	140	G 1/4" - G 3/8"	324	350	30	12x14x300

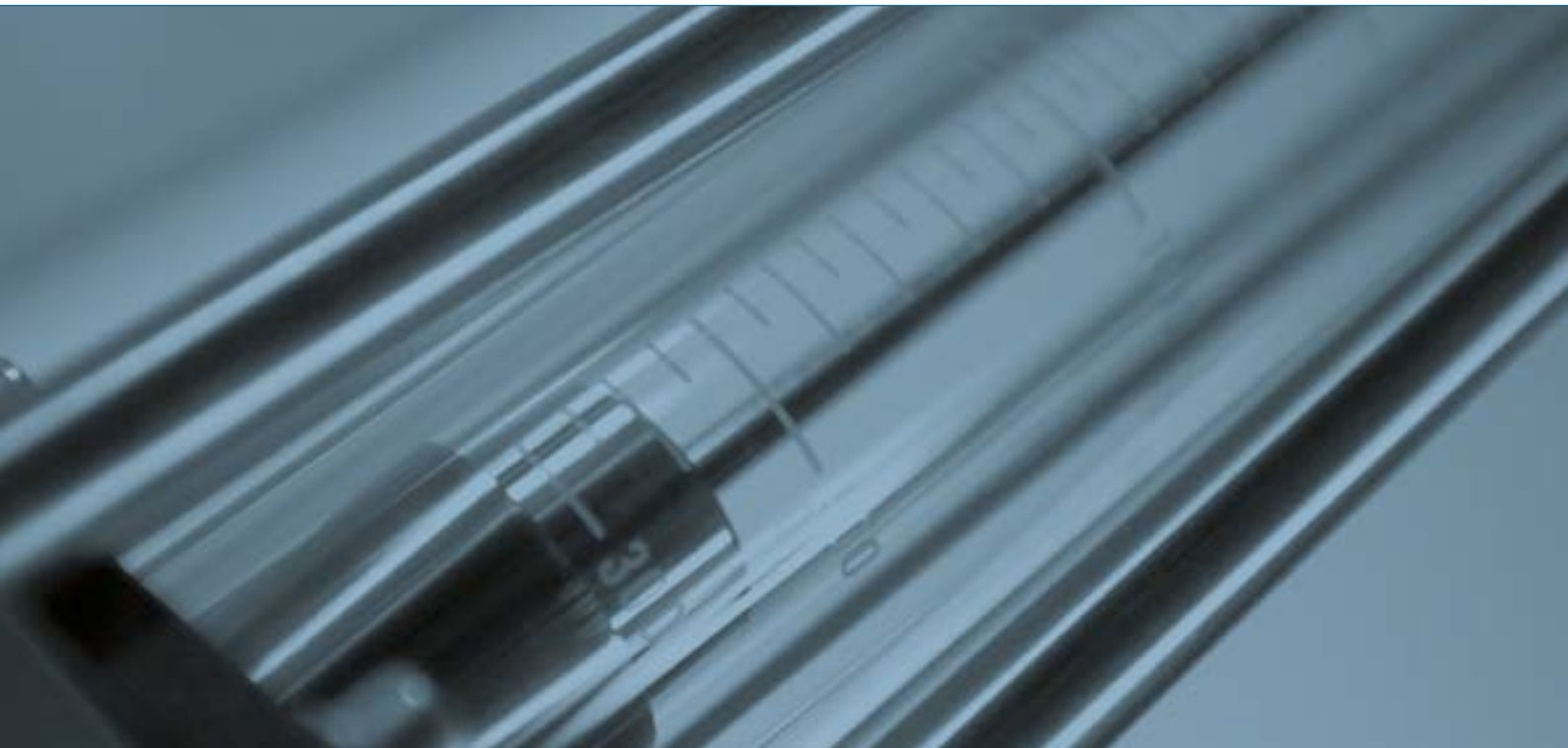

Direct reading flowmeters type **KD-KD/Z**

The flowmeters type KD-KD/Z are instant flow measuring devices suitable for little and medium flows of liquid and gaseous fluids. The flow measurement can be read with great accuracy on the graduated scale, etched on the conical borosilicate JENA glass tube. Bodies can be

flanged or threaded, with axial or square connections, with or without external protection. Other features, besides the ones already mentioned, are:

- possibility to mount the instrument anywhere along the pipeline, without need of flow correctors;

- reading accuracy: $\pm 3\%$ E.O.S.;
- resistance to pressures up to 10 bar and to considerable thermic changes.

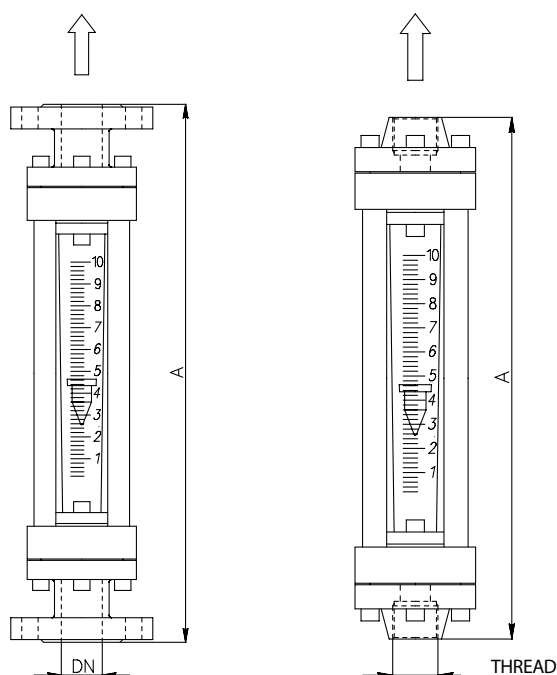

Flanged connections

Threaded connections

FEATURES

Accuracy	$\pm 3\%$ E.O.S.
Working max. pressure	10 bar
Working max. temperature with standard gaskets	metal body: 120° C. PVC body: 50° C. Polypropylene body: 100° C.

ACCESSORIES

- Proximity transducers type "A"
- External cover
- P.T.F.E. gaskets
- Square connections



TYPE	AIR Maximum flow Nm ³ /h 1013 mbar	WATER Maximum flow L/h	THREADED CONNECTIONS			FLANGED CONNECTIONS		
			METAL A	PLASTIC A	THREAD	METAL A	PLASTIC A	DN
KD/2	2,5	100 120	360	418	G 3/8" - G 1/2"	500	526	10 - 15
KD/2b	5	200	376	418	G 3/8" - G 1/2"	508	526	10 - 15
KD/3	15	300 400 500 600 800	382	418	G 1/2" - G 3/4"	506	526	15 - 20
KD/3b	20	1200 1500	382	418	G 3/4" - G 1"	506	526	20 - 25
KD/4	50	2000 2500 3500	394	426	G 3/4" - G 1"	510	530	20 - 25
KD/5	60	3000 4000	400	426	G 1" - G 1" 1/4	512	550	25 - 32
KD/5b	80	5000 6000	406	426	G 1" 1/4 - G 1" 1/2	518	561	32 - 40
KD/Z1	80	5000 6000 8000	511	531	G 1" 1/4 - G 1" 1/2	623	666	32 - 40
KD/Z2	150	10000 12000 15000	523	555	G 1" 1/2 - G 2"	627	678	40 - 50
KD/Z3	500	20000 25000 30000 40000 50000	525	567	G 2" - G 2" 1/2	637	678	50 - 65

Indirect reading flowmeters type SW

The by-pass type flowmeters of the SW series are instant flow measuring devices, suitable for medium and medium-large flows of liquid and gaseous fluids. The flow measurement can be read with great accuracy on the graduated scale,

inprinted on the conical borosilicate JENA glass tube. They can be mounted either on horizontal or vertical pipelines, with upward or downward flow, or with right or left flow.

Other features, besides the ones already mentioned are:

- possibility of mounting the measuring tube remotely, distant from the annular chamber;
- reading accuracy of about $\pm 5\%$ E.O.S;
- resistance to pressures up to 10 bar.

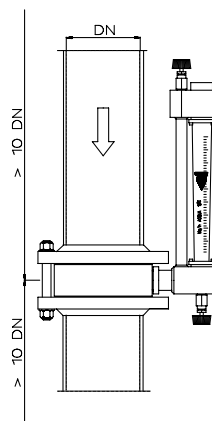
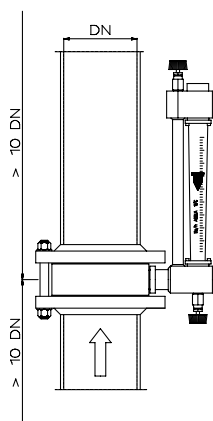
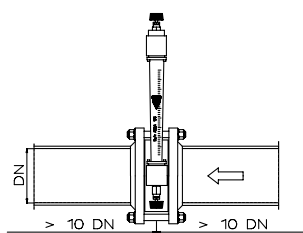
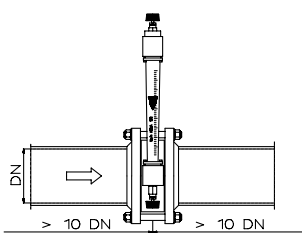

Line mounting examples

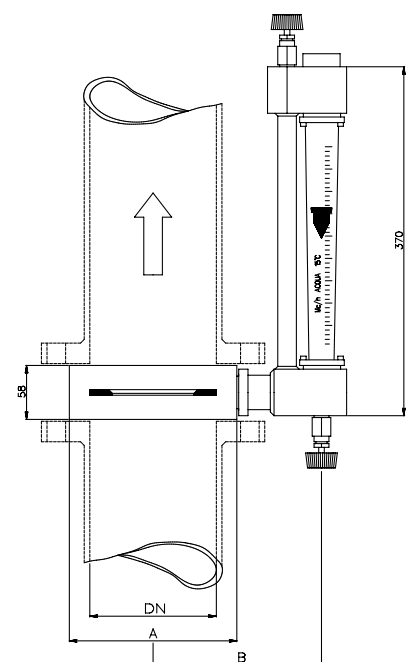



FEATURES

Accuracy	± 5% E.O.S.
Working max. pressure	10 bar
Working max. temperature with standard gaskets	metal body: 120° C. Polypropylene body: 100° C.
By-pass type needle valve (only for metal bodies)	
PMMA front cover	

ACCESSORIES

Proximity transducers type "A"
P.T.F.E. gaskets
Separate meter to be connected at distance
Construction for low pressure loss

TYPE	BODY: CARBON STEEL AND S/S					
	FOR ASA FLANGES			FOR UNI FLANGES		
	DN	A	B	DN	A	B
SW 40	1" 1/2	127	148.5	40	92	128.5
SW 50	2"	101.5	134	50	107	137.5
SW 65	2" 1/2	121.5	145.5	65	127	148.5
SW 80	3"	133.5	152	80	142	156.5
SW 100	4"	171.5	172	100	162	167
SW 125	5"	193.5	183.5	125	192	182.5
SW 150	6"	219	196.5	150	218	196
SW 200	8"	276	225.5	200	273	224

TYPE	BODY: PVC AND POLYPROPYLENE					
	FOR ASA FLANGES			FOR UNI FLANGES		
	DN	A	B	DN	A	B
SW 40	1" 1/2	127	153.5	40	150	165.5
SW 50	2"	152	167	50	165	173.5
SW 65	2" 1/2	121.5	150.5	65	127	153.5
SW 80	3"	133.5	157	80	142	161.5
SW 100	4"	171.5	177	100	162	172
SW 125	5"	193.5	188.5	125	192	187.5
SW 150	6"	219	201.5	150	218	201
SW 200	8"	276	230.5	200	273	229



Electric contacts type **A**

The electric contacts type "A" assure, when coupled to the flowmeters type KD-KD/Z, SW, LB, intervention points adjustable on the whole instrument scale. The feeders are assembled in a wheaterproof case with IP65 electric protection.



TYPE	SENSORS	ELECTRIC CONTACTS	CONTACTS ELECTRIC VALUES	AVAILABLE FOR
A 30 S	n° 1 Inductive proximity transducer	n° 1 SPDT	250V 5A 50HZ	"KD-KD/Z, SW"
A 30 D	n° 2 Inductive proximity transducers	n° 2 SPDT	250V 5A 50HZ	"KD-KD/Z, SW"
A 30 S BIS	n° 1 Inductive proximity transducer	n° 1 SPDT with double stable contact	250V 5A 50HZ	"KD-KD/Z, SW"
A 30 SN	n° 1 Inductive proximity transducer NAMUR	n° 1 SPDT	250V 5A 50HZ	"KD-KD/Z, SW"
A 30 SN BIS	n° 1 Inductive proximity transducer NAMUR	n° 1 SPDT with double stable contact	250V 5A 50HZ	"KD-KD/Z, SW"
A 30 AF	n° 1 Photocell with infra-red barrier	n° 1 SPDT with programmable time	250V 5A 50HZ	"KD-KD/Z, SW, LB"

Power: 110V/220V \pm 5% 50 Hz
 Electric case: 127x87x56 mm
 Cable connectors: PG7"



Magnetic transmission flowmeters type TM

The direct reading flowmeters type TM are instant flow measuring devices with the reading pointer magnetically coupled to the measuring device. The range can be read with high accuracy on the external dial that is contained, together with the magnetic group, in a weatherproof case made of shell mould casted aluminium. They are particularly suitable for fluids measurements, both liquid

and gaseous, in hard working conditions and they are often used in chemical, petrolchemical, pharmaceutical, food industries etc. The direct reading flowmeters type TM are suitable for the mounting on vertical pipelines with upwards flow. Other features besides the ones already mentioned are:

- carbon steel or stainless steel flanges;

- standard construction up to PN10;
- max. working temperature: 120° C.;
- accuracy: $\pm 5\%$ E. O. S.;
- graduated scale stating the range or the percentage.

Instruments with other features can be manufactured at request.

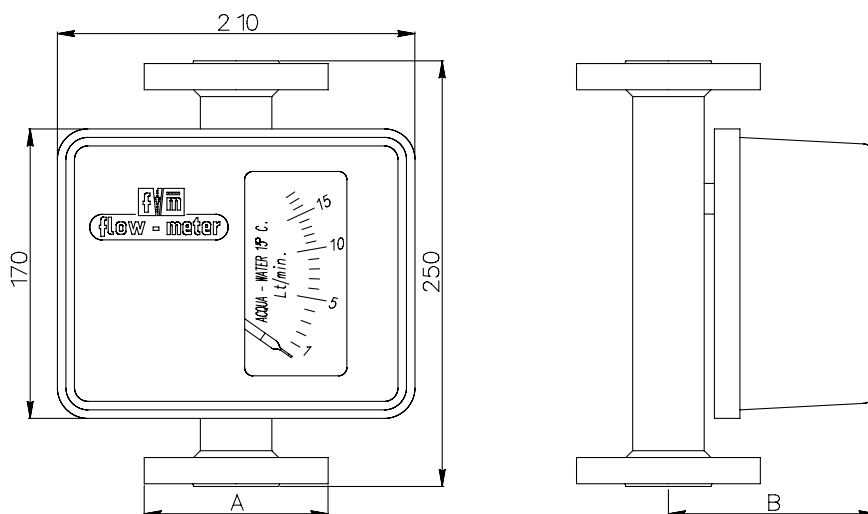

Type TM



FEATURES

Accuracy	± 5% V.F.S.
Working max. pressure	PN 10
Working max. temperature	120° C.

ACCESSORIES

Plastic body suitable for the use with corrosive fluids
Float made of HASTELLOY C or TITANIUM
Construction up to PN64

TYPE	WATER Maximum flow m ³ /h	AIR Maximum flow Nm ³ /h 1013 mbar	FLANGE A		B
			UNI PN 6 ÷ PN 64	ANSI 150 LB ÷ 300 LB	
TM 15	1,5	45	DN 15	1/2"	125,5
TM 20	2	55	DN 20	3/4"	128
TM 25	4	120	DN 25	1"	132
TM 32	6	180	DN 32	1" 1/4	136
TM 40	10	300	DN 40	1" 1/2	139
TM 50	15	400	DN 50	2"	145
TM 65	25	750	DN 65	2" 1/2	151,5
TM 80	40	1200	DN 80	3"	159,5
TM 100	90	2500	DN 100	4"	182



Magnetic transmission flowmeters type TM/D

The TM/D series flowmeters for direct readings are instant flow meters with magnetic coupling of the measuring element. The flow rate can be read with great accuracy on the external LCD which, together with the magnetic unit, is held in a sealed, mould-cast aluminium case. Particularly suitable for measuring fluids, both liquid and gaseous, under heavy working conditions, these instruments can be used in a wide range of applications in the chemical, petrochemical, pharmaceutical and food processing industries, etc. The TM/D series flow meters for direct readings are designed to be fitted on vertical pipes with rising flows. They can also supply clean electrical exchange signals for flow alarms (No alarm, minimum contact (Q1), maximum contact (Q2), minimum and maximum contact (Q1 + Q2),

bistable contact (Qmin and Qmax)), which can be set with a keypad on the entire scale, as well as a 4-20 mA or 0-10 V electrical output signal proportional to the flow rate, besides displaying the total flow. By pressing the pushbuttons SET1, SET2 and 123 it is possible to set:

- the time within which the alarm signal must be triggered (from 0 to 10 s);
- the enabling or disabling of the alarm buzzer: if the set limits are exceeded an acoustic warning can be emitted, which can be turned OFF with a pushbutton, or the alarm can be signalled merely by the flashing of the alarm indicator and the LED on the MUTE pushbutton;
- the flow rate indication delay time (from 0 to 10 s);
- the output signal delay time (from 0 to 10 s);

- the selection of the output signal (4-20 mA or 0-10 V);
- the toggling ON/OFF of the decimal figure indicator;
- the keypad block, to avoid accidental or unwanted commands.

Other features, besides those already mentioned are:

- carbon steel or stainless steel flange
 - standard construction up to PN10;
 - maximum working temperature: 120° C.;
 - accuracy: $\pm 5\%$ E.O.S.;
 - graduated flow scale or percentage.
- Instruments with other features can be provided on request.

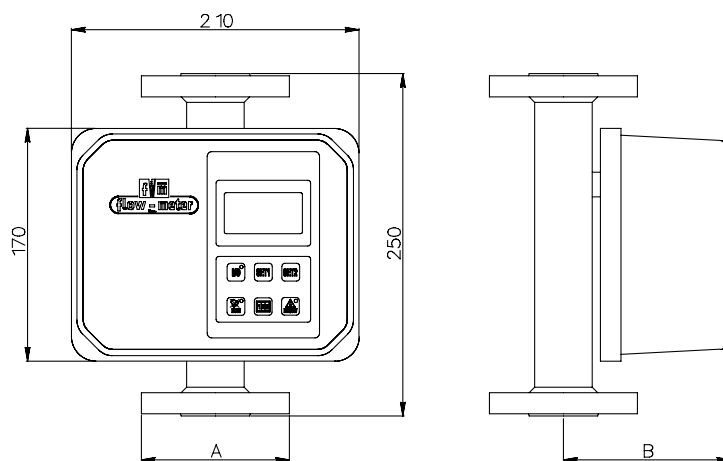

Type TM/D



FEATURES

Accuracy	± 5% V.F.S.
Max. working pressure	PN 10
Max. working temperature	120° C.

ELECTRICAL SPECIFICATIONS

Voltage	235 V A.C. ± 10% 50-60 Hz
Power	15 VA
Connector	MIL-C 26482 (US)
IP class	IP 66
Software switch push button on front panel (I/O)	

ACCESSORIES

Plastic body suitable for the use with corrosive fluids
Float made of HASTELLOY C or TITANIUM
Construction up to PN 64

ELECTRICAL OUTPUT SIGNALS

Exchange contacts SPDT	Max. 250V A.C. 0,5A
Analog voltage output	0-10 V D.C.
Maximum charge	1 KOhm
Analog current output	4-20 mA
Minimum charge	250 Ohm

TYPE	WATER Maximum flow m ³ /h	AIR Maximum flow Nm ³ /h. 760 mmHg	FLANGE A		B
			UNI PN 6 ÷ PN 10	ANSI 150 LB ÷ 300 LB	
TM/D 15	1,5	45	DN 15	1/2"	125,5
TM/D 20	2	55	DN 20	3/4"	128
TM/D 25	4	120	DN 25	1"	132
TM/D 32	6	180	DN 32	1" 1/4	136
TM/D 40	10	300	DN 40	1" 1/2	139
TM/D 50	15	400	DN 50	2"	145
TM/D 65	25	750	DN 65	2" 1/2	151,5
TM/D 80	40	1200	DN 80	3"	159,5
TM/D 100	90	2500	DN 100	4"	182

Magnetic transmission flowmeters type TMW

The indirect reading flowmeters type TMW are instant flow measuring devices with the reading pointer magnetically coupled to the measuring device. The range can be read with high accuracy on the external dial that is contained, together with the magnetic group, in a weatherproof case made of shell mould casted aluminium. They are particularly suitable for fluids measurements, both liquid and

gaseous, in hard working conditions and they are often used in chemical, petrochemical, pharmaceutical, food industries etc.

The indirect reading flowmeters type TMW can be mounted both on horizontal pipelines, with right or left flow, and on vertical pipelines, with upwards or downwards flow. Other features besides the ones already mentioned are:

- carbon steel or stainless steel body;
 - standard construction up to PN10;
 - max. working temperature: 120° C.;
 - accuracy: $\pm 5\%$ E.O.S.;
 - graduated scale stating the range or the percentage.
- Instruments with other features can be manufactured at request.

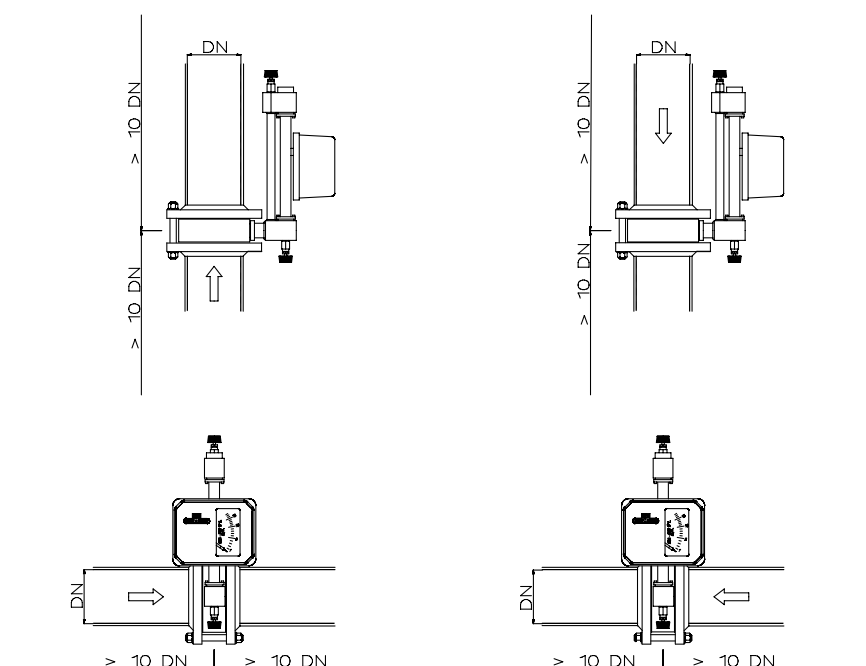

Type TMW line mounting examples



FEATURES

Accuracy	± 5% V.F.S.
Max. working pressure	PN 10
Max. working temperature	120° C.
Cut-off tap by-pass type	

ACCESSORIES

P.T.F.E. gaskets
Separate measuring device to be connected at distance
Float made of HASTELLOY C or TITANIUM
Construction up to PN 64

TYPE	WATER Maximum flow m ³ /h	AIR Maximum flow Nm ³ /h 1013 mbar	FLANGE A	
			UNI PN 6 ÷ PN 64	ANSI 150 LB ÷ 300 LB
TMW 40	30	450	DN 40	1" 1/2
TMW 50	45	700	DN 50	2"
TMW 65	75	1200	DN 65	2" 1/2
TMW 80	110	1800	DN 80	3"
TMW 100	170	2800	DN 100	4"
TMW 125	270	4500	DN 125	5"
TMW 150	400	6500	DN 150	6"
TMW 200	700	11000	DN 200	8"
TMW 250	1100	18000	DN 250	10"

Magnetic transmission flowmeters type TMW/D

The TMW/D series flowmeters for indirect readings are instant flow meters with magnetic coupling of the measuring element.

The flow rate can be read with great accuracy on the external LCD which, together with the magnetic unit, is held in a sealed, mould-cast aluminium case.

Particularly suitable for measuring fluids, both liquid and gaseous, under heavy working conditions, these instruments can be used in a wide range of applications in the chemical, petrochemical, pharmaceutical and food processing industries, etc.

The indirect reading flow meter type TMW/D can be mounted both on horizontal pipelines, with right or left flows, and on vertical pipelines, with upwards or downwards flow.

They can also supply clean electrical exchange

signals for flow alarms (No alarm, minimum contact (Q1), maximum contact (Q2), minimum and maximum contact (Q1 + Q2), bistable contact (Qmin and Qmax)), which can be set with a keypad on the entire scale, as well as a 4-20 mA or 0-10 V electrical output signal proportional to the flow rate, besides displaying the total flow.

By pressing the pushbuttons SET1, SET2 and 123 it is possible to set:

- the time within which the alarm signal must be triggered (from 0 to 10 s);
 - the enabling or disabling of the alarm buzzer: if the set limits are exceeded an acoustic warning can be emitted, which can be turned OFF with a pushbutton, or the alarm can be signalled merely by the flashing of the alarm indicator and the LED on the MUTE pushbutton;
 - the flow rate indication delay time (from 0 to 10 s);
 - the output signal delay time (from 0 to 10 s);
 - the selection of the output signal (4-20 mA or 0-10 V);
 - the toggling ON/OFF of the decimal figure indicator;
 - the keypad block, to avoid accidental or unwanted commands.
 - Other features, besides those already mentioned are:
 - Carbon steel or stainless steel body
 - standard construction up to PN10;
 - maximum working temperature: 120° C.;
 - accuracy: $\pm 5\%$ E.O.S.;
 - graduated flow scale or percentage.
- Instruments with other features can be provided on request.

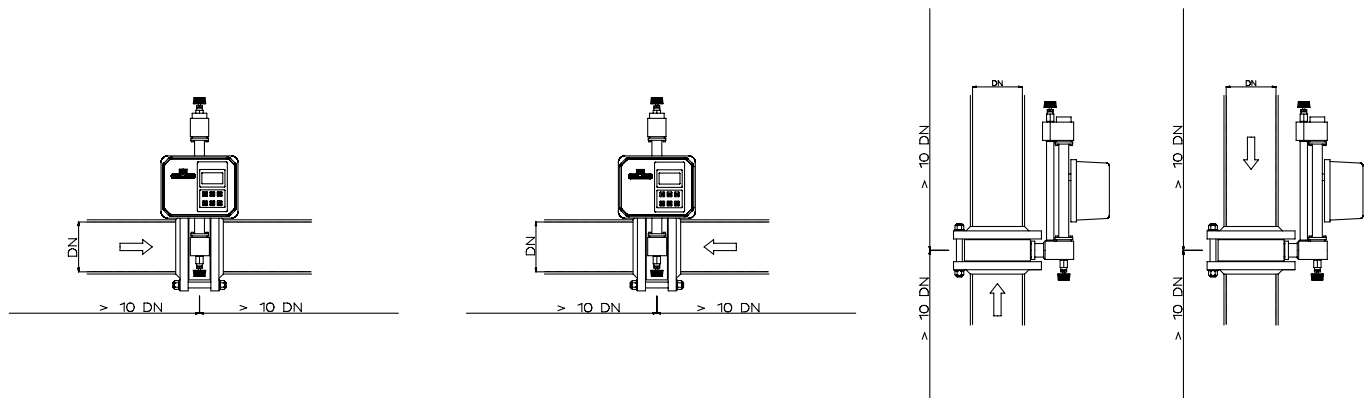

Type TMW/D line mounting examples



FEATURES

Accuracy	± 5% V.F.S.
Max. working pressure	PN 10
Max. working temperature	120° C.
Cut-off tap by-pass type	

ACCESSORIES

Construction up to PN 64
Float made of HASTELLOY C or TITANIUM
P.T.F.E. gaskets
Separate measuring device to be connected at distance

ELECTRICAL SPECIFICATIONS

Voltage	235 V.A.C. ± 10% 50-60 Hz
Power	15 VA
Connector	MIL-C 26482 (US)
IP class	IP 66
Software switch push button on front panel (I/O)	

ELECTRICAL OUTPUT SIGNALS

Exchange contacts SPDT	Max. 250 V.A.C. 0,5 A
Analog voltage output	0-10 V
Maximum charge	1 KOhm
Analog current output	4-20 mA
Minimum charge	250 Ohm

TYPE	WATER maximum flow m³/h	AIR maximum flow Nm³/h 1013 mbar	FLANGE A	
			UNI PN 6 ÷ PN 64	ANSI 150 LB ÷ 300 LB
TMW/D 40	30	450	DN 40	1" 1/2
TMW/D 50	45	700	DN 50	2"
TMW/D 65	75	1200	DN 65	2" 1/2
TMW/D 80	110	1800	DN 80	3"
TMW/D 100	170	2800	DN 100	4"
TMW/D 125	270	4500	DN 125	5"
TMW/D 150	400	6500	DN 150	6"
TMW/D 200	700	11000	DN 200	8"
TMW/D 250	1100	18000	DN 250	10"